



Internationales Fahrturnier
International Driving Event
CAI 3*/CAI 2*
Nationales Fahrturnier CAN
09.04.-12.04.2026



Münsterländer
MannschaftsCup



Map of showground

Alberts Kids-Cup 2026

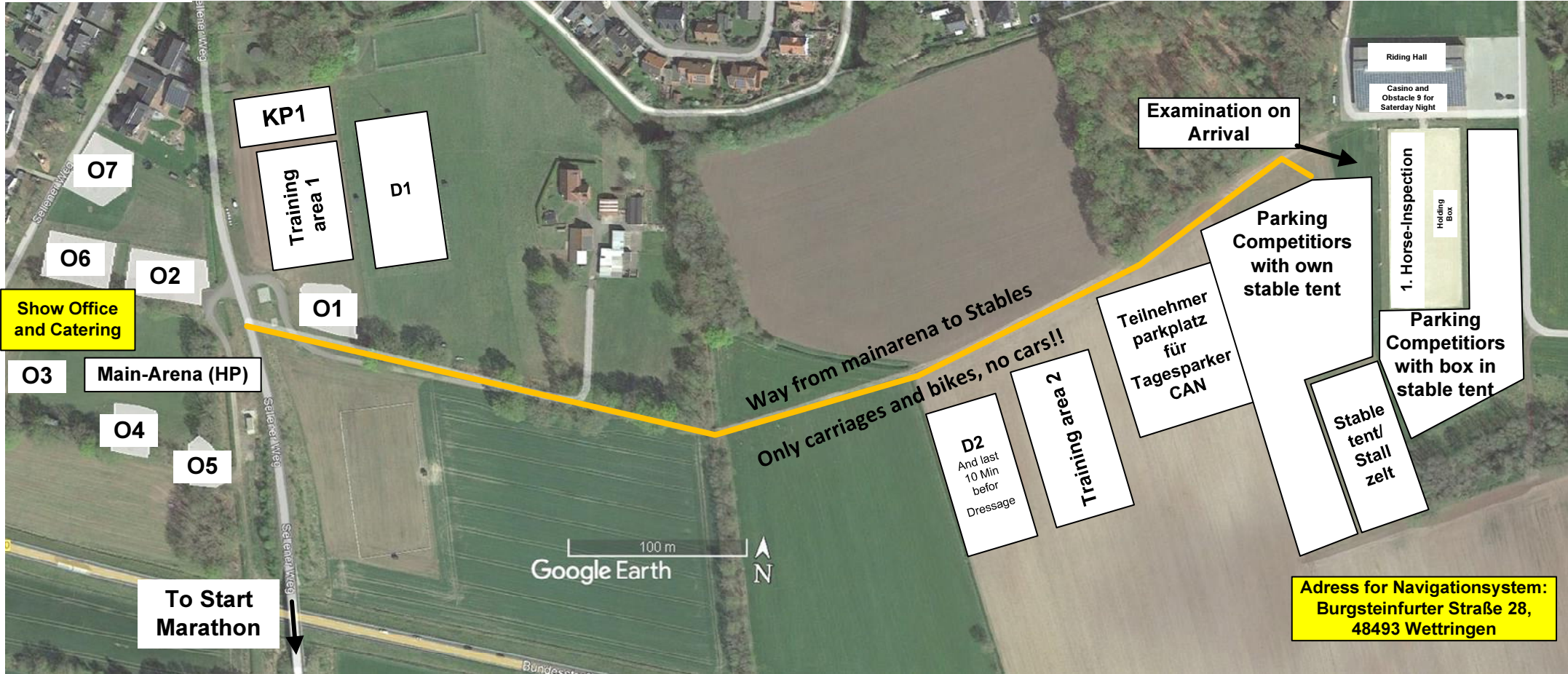

Adress for Navigationsystem:
Burgsteinfurter Straße 28,
48493 Wettringen

Downloadlink
WBO
Dressur/Kegel

Downloadlink
KI.A
Geländeunterlagen

Downloadlink
KI.A
Kegelfahren

Downloadlink
KI.M
Geländeunterlagen

Downloadlink
KI.M
Kegelfahren

Downloadlink
2*
Marathon

Downloadlink
2*
Cones

Downloadlink
3*
Marathon

Downloadlink
3*
Cones

Timetable/
Zeiteinteilung
Results/
Ergebnisse





**Internationales Fahrturnier
International Driving Event CAI 3*/CAI 2*
Nationales Fahrturnier CAN**

09.04.-12.04.2026

WarmUpTrack

(Recommended for all international classes)

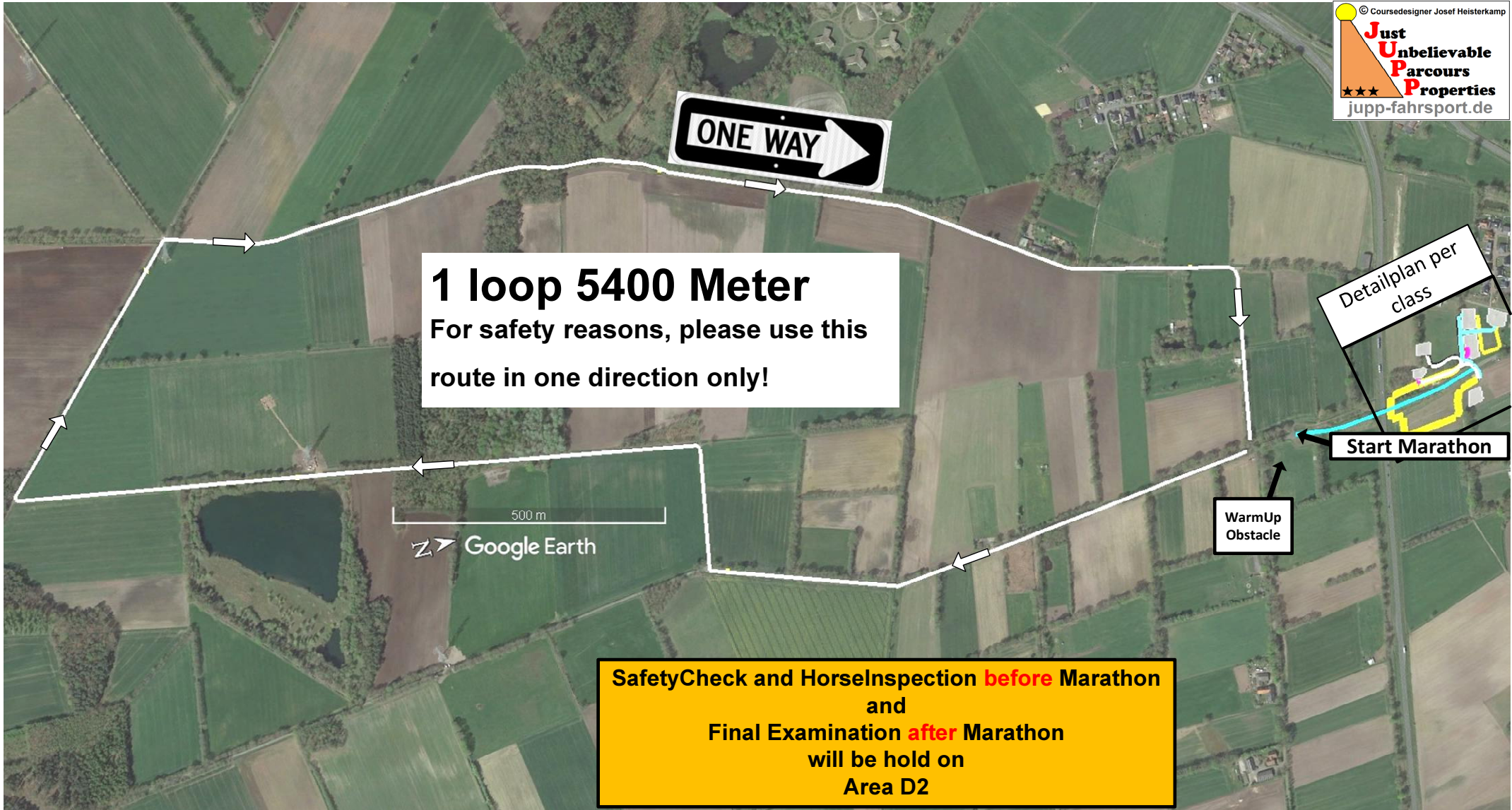



Internationales Fahrturnier
International Driving Event CAI 3*/CAI 2*
Nationales Fahrturnier CAN

09.04.-12.04.2026

Marathon 2* 4830 Meter

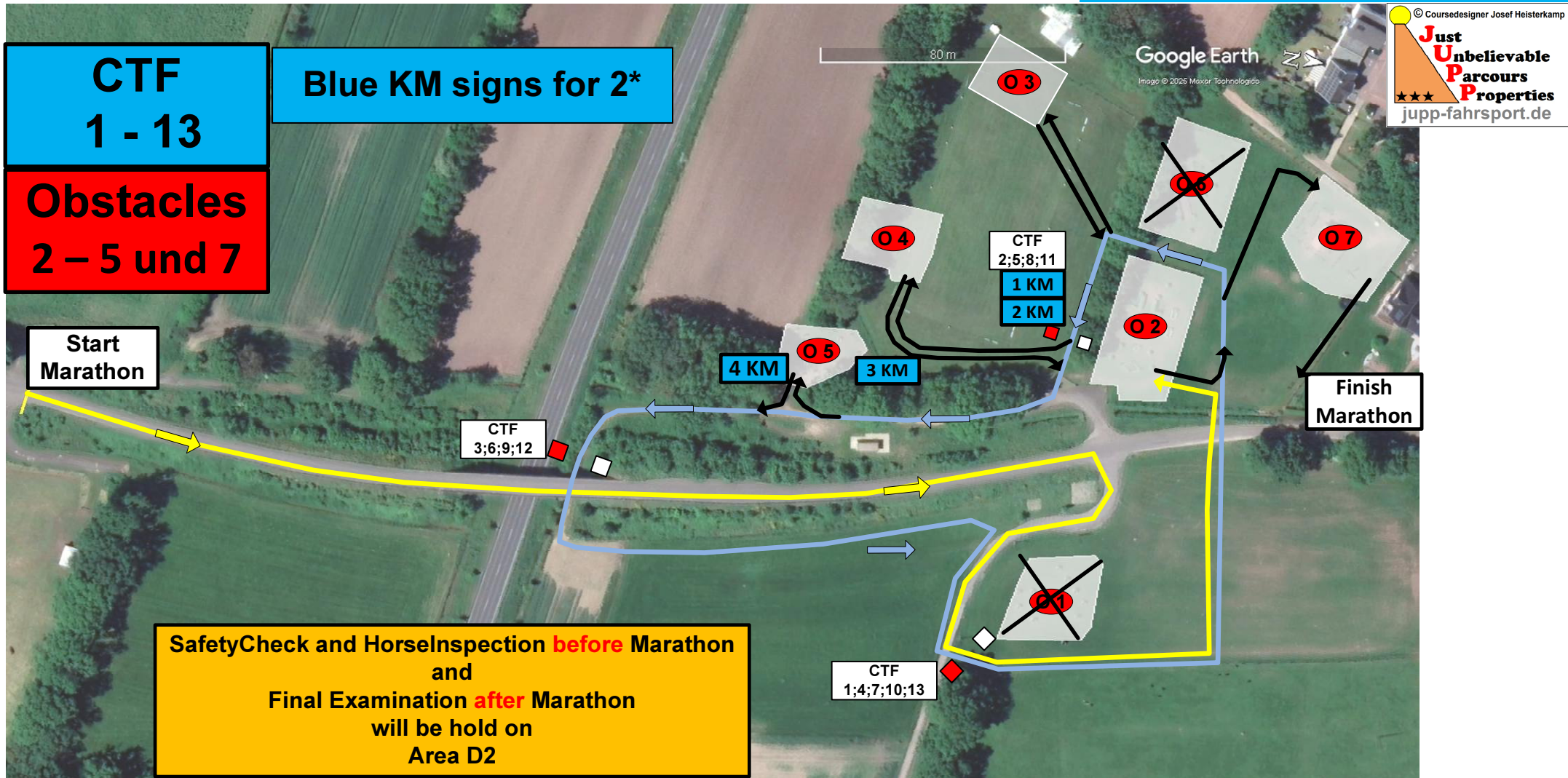

Legende: Start Marathon / CTF1 / O2 / CTF2 / 1 KM / CTF3 / CTF4 / O3 / CTF5 / 2 KM / CTF6 / CTF7 / CTF8 / O4 / 3 KM / CTF9 / CTF10 / CTF11 / O5 / 4 KM / CTF12 / CTF13 / O7 / Finish Marathon. 4830 Meter



Internationales Fahrturnier
 International Driving Event CAI 3*/CAI 2*
 Nationales Fahrturnier CAN

09.04.-12.04.2026

Marathon 3*
5880 Meter

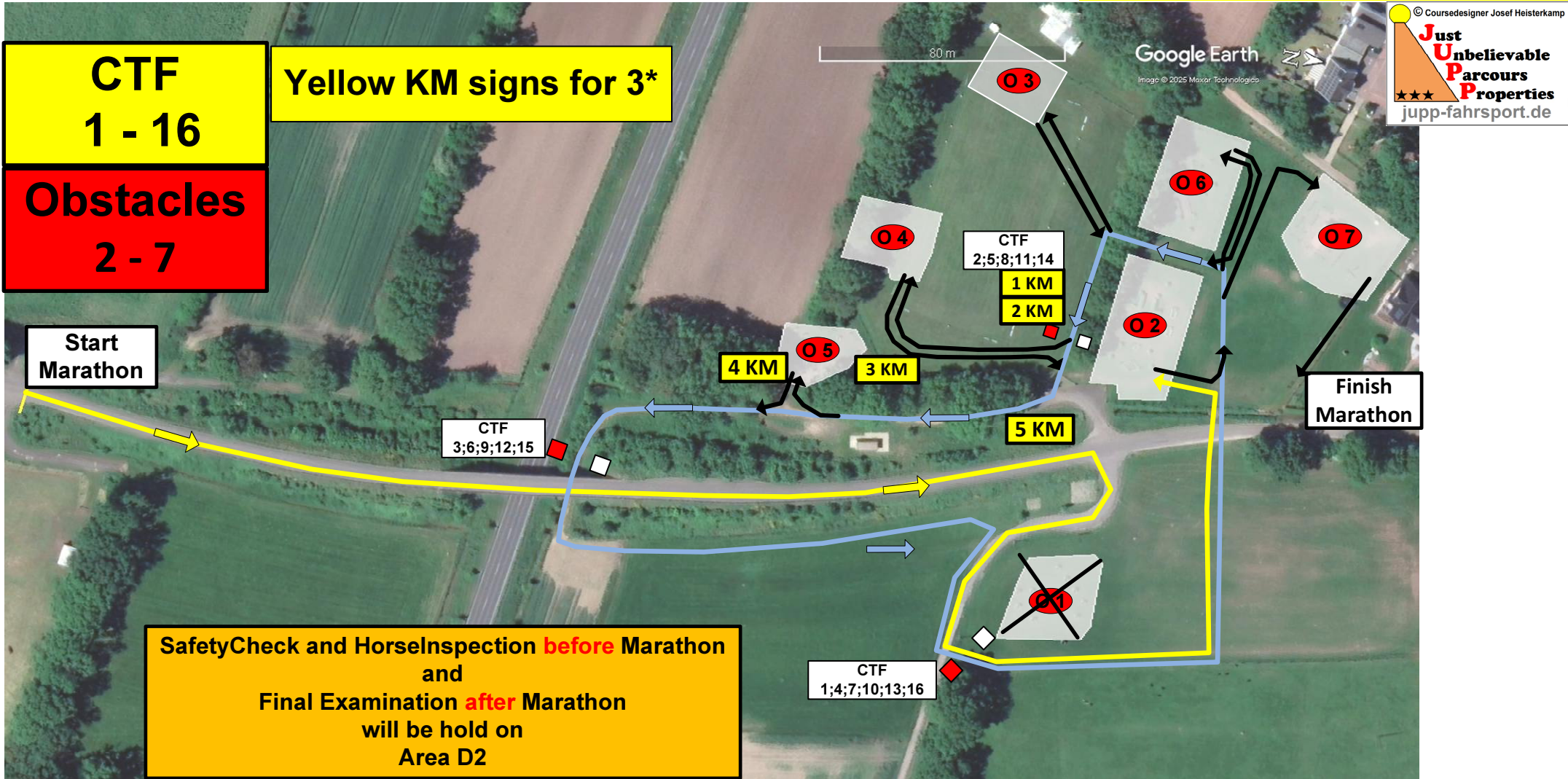

Legende: Start Marathon / CTF1 / O2 / CTF2 / 1 KM / CTF3 / CTF4 / O3 / CTF5 / 2 KM / CTF6 / CTF7 / CTF8 / O4 / 3 KM / CTF9 / CTF10 / CTF11 / O5 / 4 KM / CTF12 / CTF13 / O6 / CTF14 / 5 KM / CTF15 / CTF16 / O7 / Finish Marathon. 5880 Meter



Internationales Fahrturnier International Driving Event CAI 3*/CAI 2* Nationales Fahrturnier CAN

09.04.-12.04.2026

Aufwärmstrecke für Klasse A und M (National, gem §752 LPO)





Internationales Fahrturnier
International Driving Event CAI 3*/CAI 2*
Nationales Fahrturnier CAN

09.04.-12.04.2026

HS KI. A
(Hindernisstrecke g. §752LPO)
3800 Meter

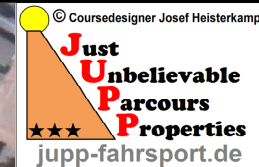

Pflichttore
1 - 10

Hindernisse
1;3;5;6

Weiße KM Schilder für
KI.A

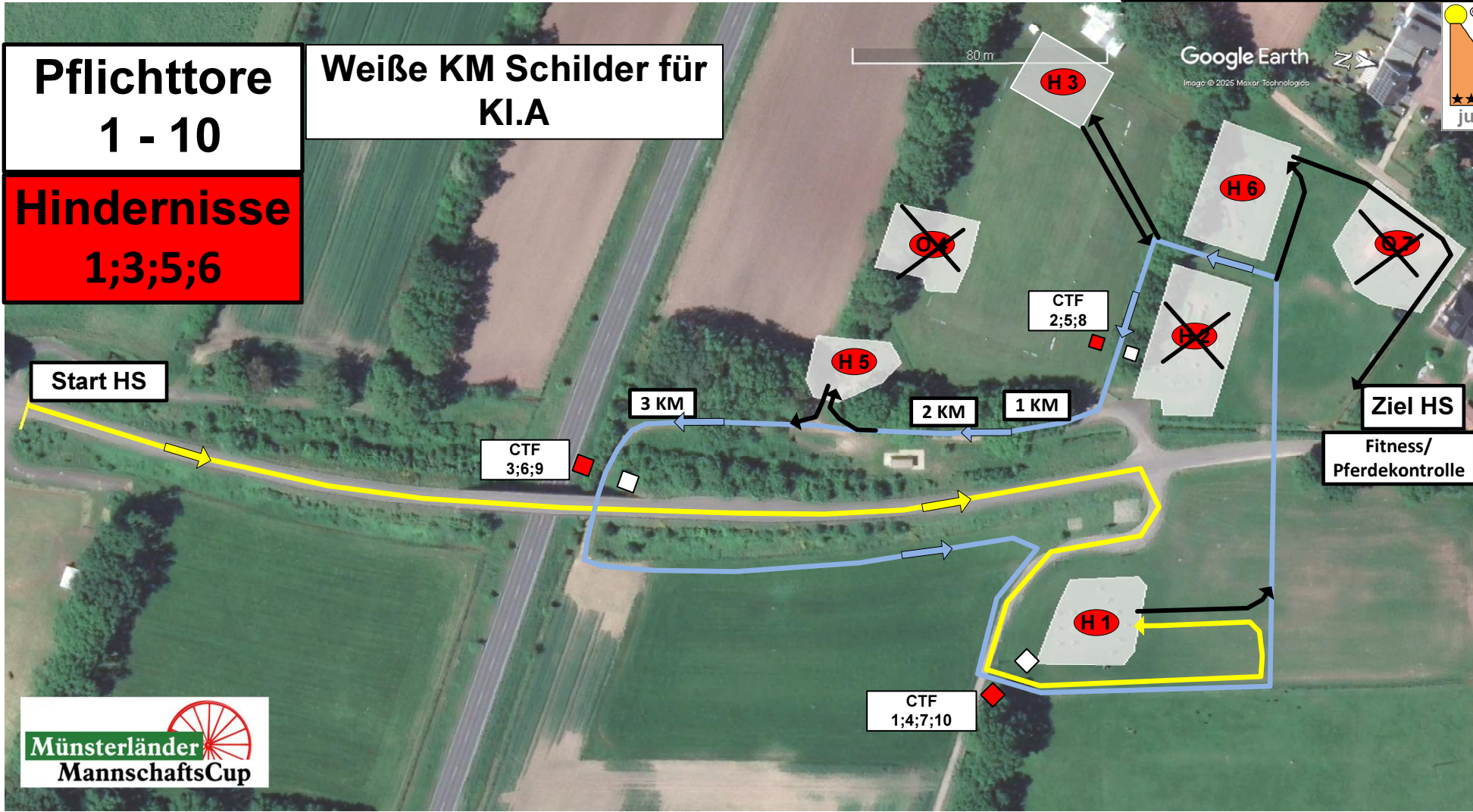

Legende: Start HS / CTF1 / **H1** / CTF2 / **1 KM** / CTF3 / CTF4 / **H3** / CTF5 / **2 KM** / CTF6 / CTF7 / CTF8 / **H5** / **3 KM** / CTF9 / CTF10 / **H6** / ZIEL HS. 3800 Meter



Internationales Fahrturnier
International Driving Event CAI 3*/CAI 2*
Nationales Fahrturnier CAN

09.04.-12.04.2026

HS KI. M
(Hindernisstrecke g. §752LPO)
4710 Meter

Pflichttore
1 - 13

Weißer KM Schilder für
KI.M

Hindernisse
1-3;5;6

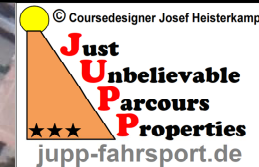
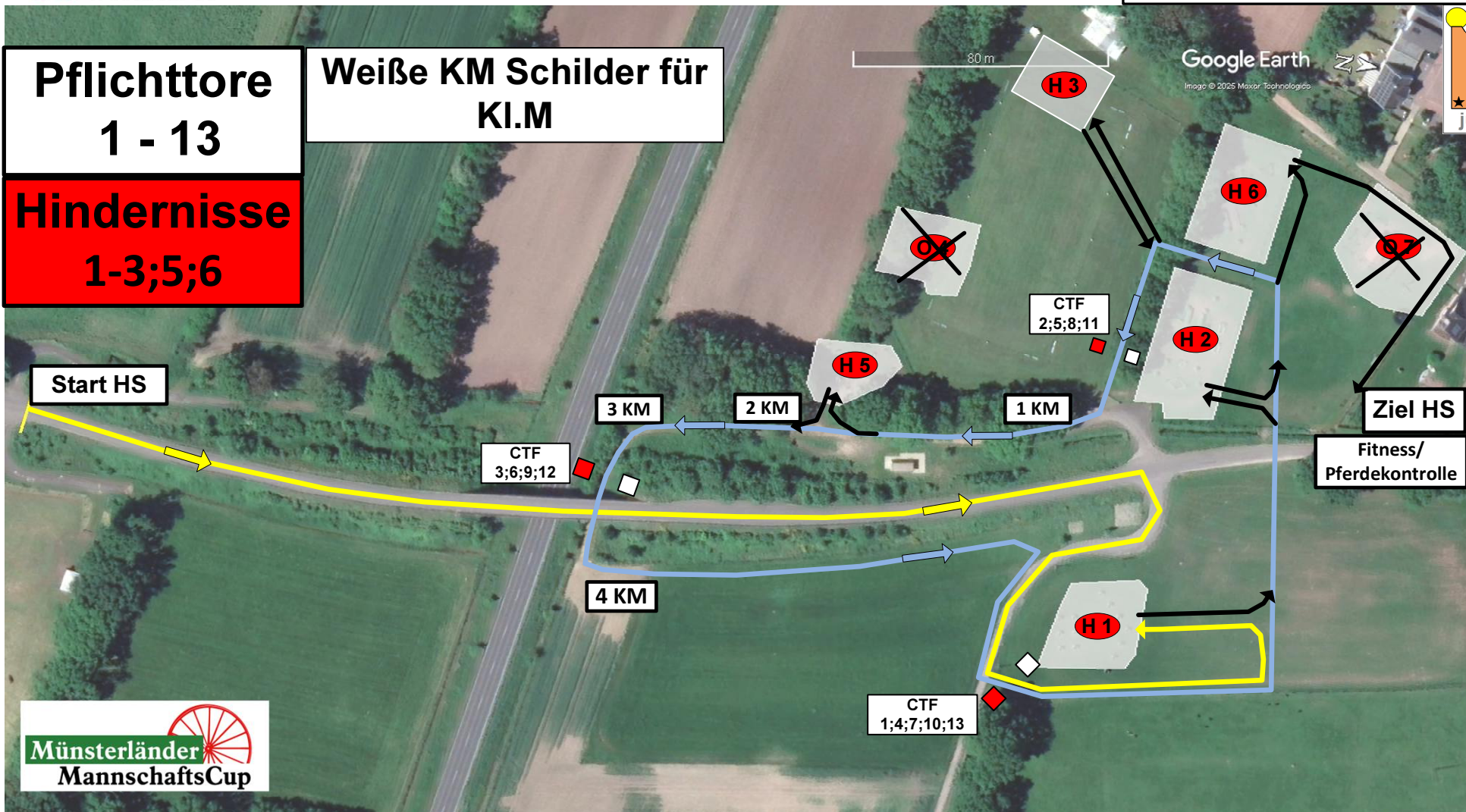

Legende: Start HS / CTF1 / **H1** / CTF2 / **1 KM** / CTF3 / CTF4 / **H2** / CTF5 / **2 KM** / CTF6 / CTF7 / **H3** / CTF8 / **3 KM** / CTF9 / CTF10 / CTF11 / **H5** / CTF12 / **4 KM** / CTF13 / **H6** / ZIEL HS. 4710 Meter



Times Marathon Geländezeiten

CAI 3* H1 / H2 HORSES Comp. Nr.: 14 / 18	Length in Meter	Tempo KM/h	Minimum Time h:min:sec	Time allowed h:min:sec	Maximum Time h:min:sec	Compulsory Turning Flags	Obstacles
Marathon Phase	5880	14	00:22:12	00:25:12	00:50:24	CTF 1-16	2; 3; 4; 5; 6; 7
CAI 2* H1 HORSES Comp. Nr.: 10	Länge in Meter	Tempo KM/h	Minimum Time h:min:sec	Time allowed h:min:sec	Maximum Time h:min:sec	Compulsory Turning Flags/ Pflichttore	Obstacles
Marathon Phase	4830	13	00:19:18	00:22:18	00:44:35	CTF 1-13	2; 3; 4; 5; 7
CAI 2* P1/P2 PONYS Comp. Nr.: 2 / 6	Länge in Meter	Tempo KM/h	Minimum Time h:min:sec	Time allowed h:min:sec	Maximum Time h:min:sec	Compulsory Turning Flags/ Pflichttore	Obstacles
Marathon Phase	4830	12	00:21:09	00:24:09	00:48:18	CTF 1-13	2; 3; 4; 5; 7
Klasse A national PFERDE Prfg. Nr.: 28;36	Länge in Meter	Tempo KM/h	Minimum Time h:min:sec	Time allowed h:min:sec	Maximum Time h:min:sec	Compulsory Turning Flags/ Pflichttore	Obstacles/ Hindernisse
Aufwärmstrecke	5400	12	00:25:00	00:27:00	00:32:24	CTF 1	
Zwangspause				00:10:00			
Hindernisstrecke	3800	13	00:14:32	00:17:32	00:35:05	CTF 1 - 10	1; 3; 5; 6
Klasse A national PONYS Prfg. Nr.: 24;32	Länge in Meter	Tempo KM/h	Minimum Time h:min:sec	Time allowed h:min:sec	Maximum Time h:min:sec	Compulsory Turning Flags/ Pflichttore	Obstacles/ Hindernisse
Aufwärmstrecke	5400	11	00:27:27	00:29:27	00:35:21	CTF 1	
Zwangspause				00:10:00			
Hindernisstrecke	3800	12	00:16:00	00:19:00	00:38:00	CTF 1 - 10	1; 3; 5; 6
Klasse M national PONYS Prfg. Nr.: 40	Länge in Meter	Tempo KM/h	Minimum Time h:min:sec	Time allowed h:min:sec	Maximum Time h:min:sec	Compulsory Turning Flags/ Pflichttore	Obstacles/ Hindernisse
Aufwärmstrecke	5400	11	00:27:27	00:29:27	00:35:21	CTF 1	
Zwangspause				00:10:00			
Hindernisstrecke	4710	12	00:20:33	00:23:33	00:47:06	CTF 1 - 13	1; 2; 3; 5; 6



Internationales Fahrturnier
International Driving Event
CAI 3*/CAI 2*
Nationales Fahrturnier
CAN
09.04.-12.04.2026

Hindernis **1**
Obstacle

Geländefahren Kl. M
Prfg.Nr: 40 **Tore A-E**

Geländefahren Kl. A
Prfg.Nr: 2; 6 und 10 nur **Tore A-D**



Not for CAI 3*

Not for CAI 2*

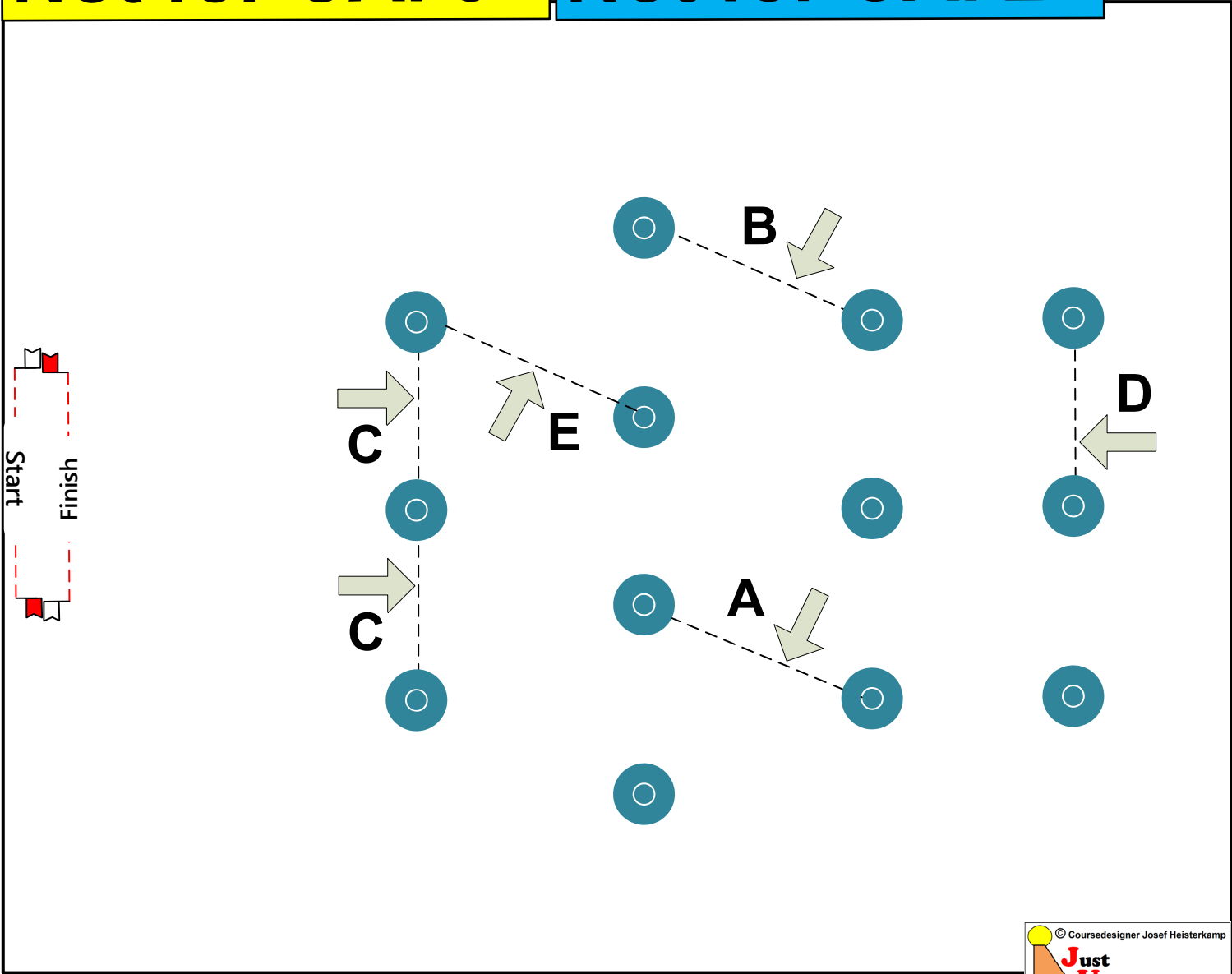



Internationales Fahrturnier
International Driving Event
CAI 3*/CAI 2*
Nationales Fahrturnier
CAN
09.04.-12.04.2026

Hindernis
Obstacle **2**

Powered by:



CAI 3*
CAI 2*

Wall

Geländefahren Kl. M Prfg.Nr: 40 nur

Tore A-E

Nicht für Kl.A!

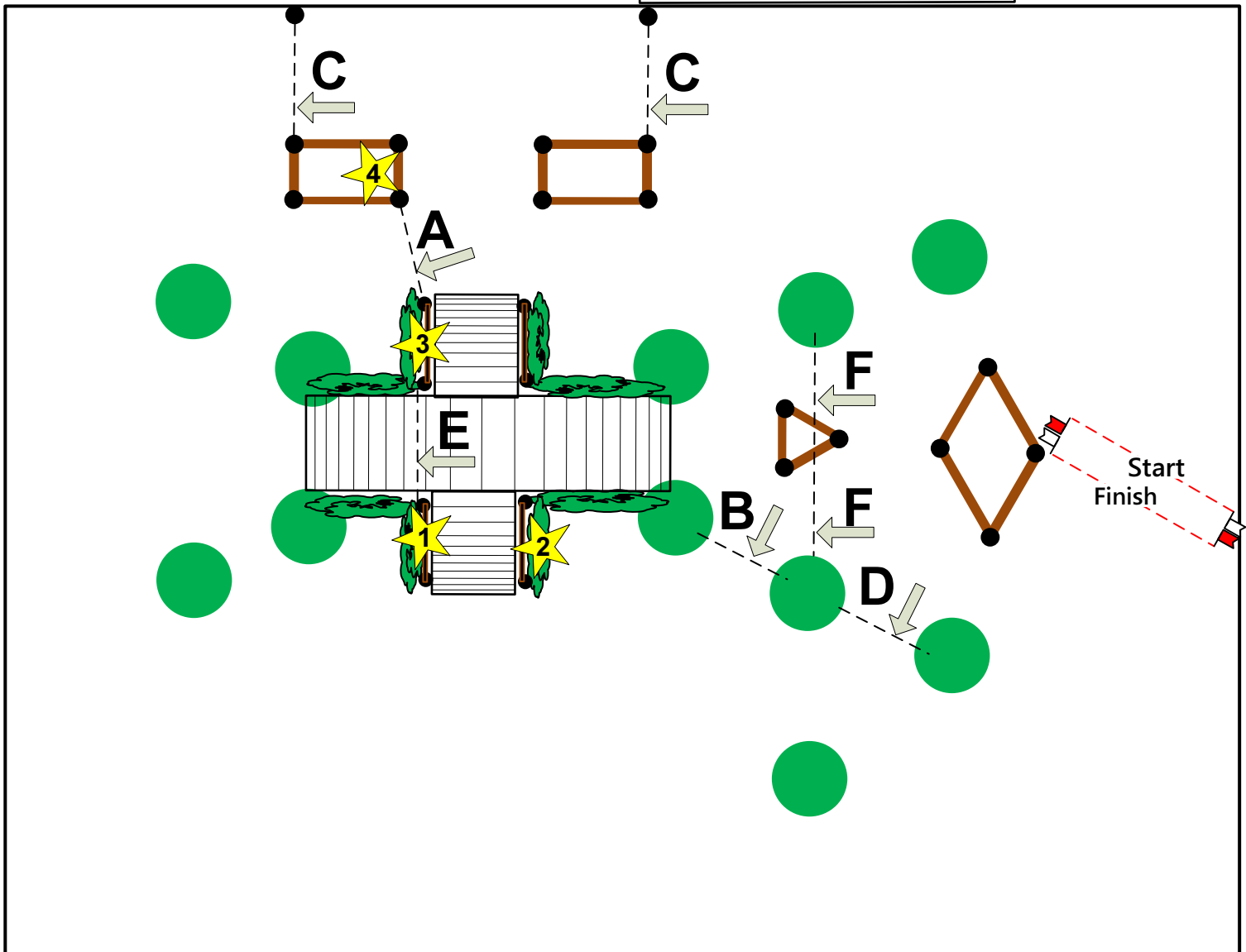

= 4 Knock Down

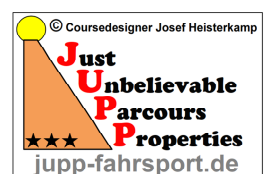



Internationales Fahrturnier
 International Driving Event
 CAI 3*/CAI 2*
 Nationales Fahrturnier
 CAN
 09.04.-12.04.2026

Hindernis
Obstacle **3**

Powered by:

Meister
Schophuis
 Zimmerei Dachdeckerei

Geländefahren Kl. M Prfg.Nr: 40 nur

Tore A-E

Geländefahren Kl. A Prfg.Nr: 2; 6 und 10 nur

Tore A-D

CAI 3* **CAI 2***

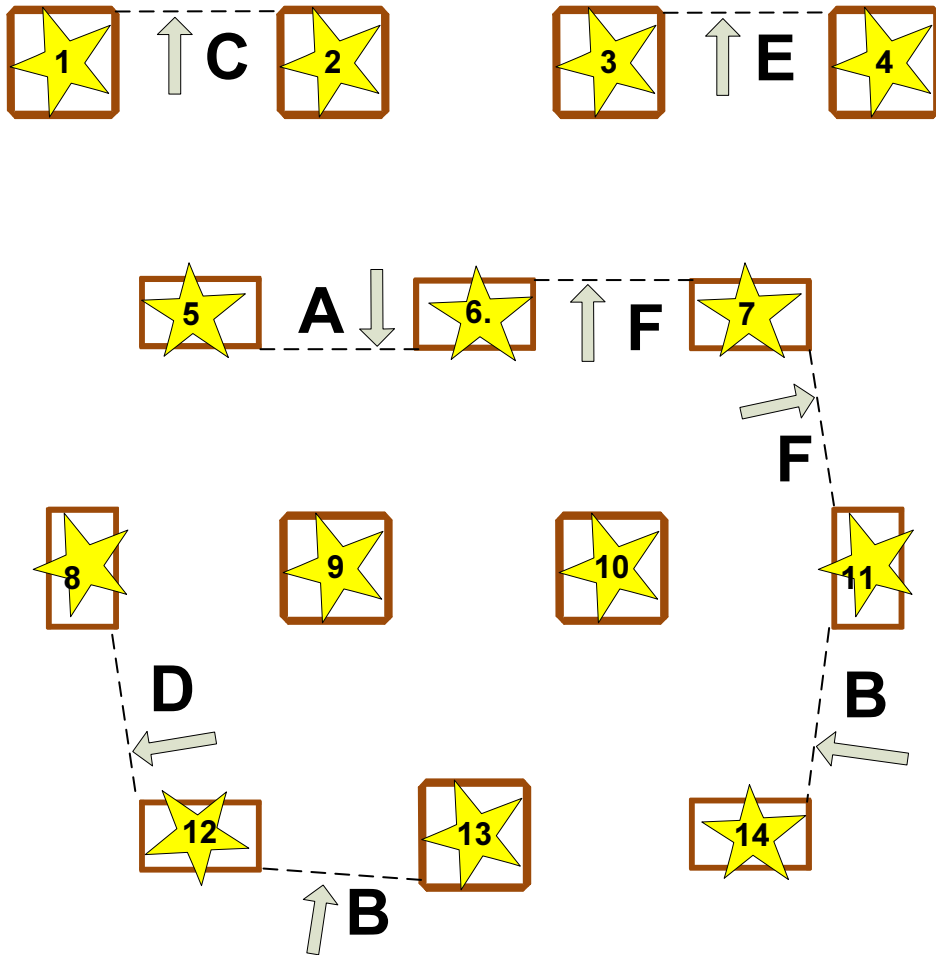

Start / Finish

= 14 Knock Down

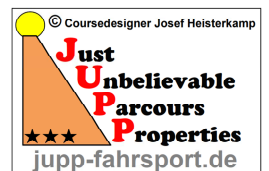



Internationales Fahrturnier
International Driving Event
CAI 3*/CAI 2*
Nationales Fahrturnier
CAN
09.04.-12.04.2026

Hindernis
Obstacle **4**

Powered by:



Märchenwald

CAI 3*
CAI 2*

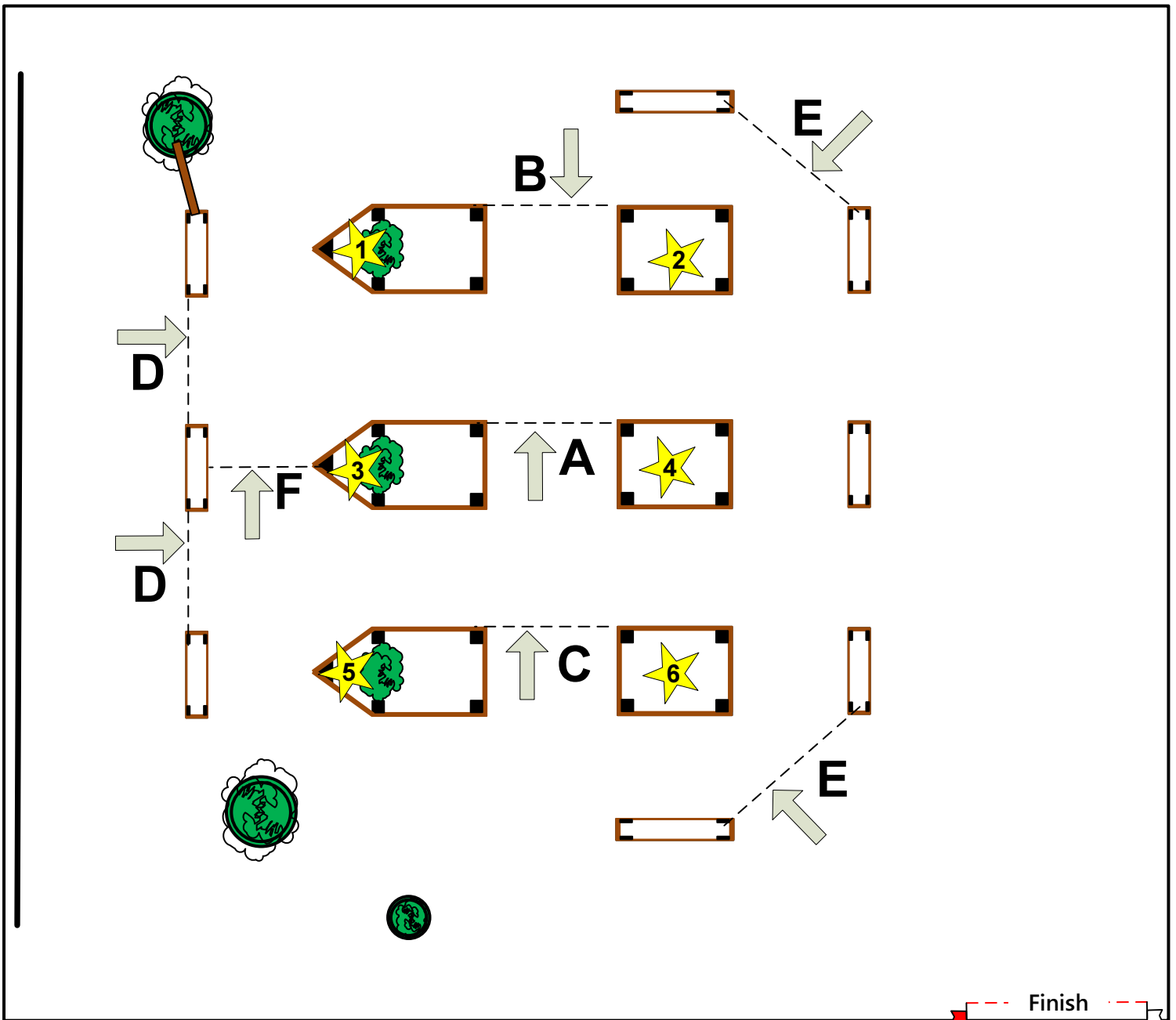



Internationales Fahrturnier
International Driving Event
CAI 3*/CAI 2*
Nationales Fahrturnier
CAN
09.04.-12.04.2026

Hindernis
Obstacle **5**

Powered by:



CAI 3*
CAI 2*

Menzel's
Wassergraben

Geländefahren Kl. M Prfg.Nr: 40 nur

Tore A-E

Geländefahren Kl. A Prfg.Nr: 2; 6 und 10 nur

Tore A-D

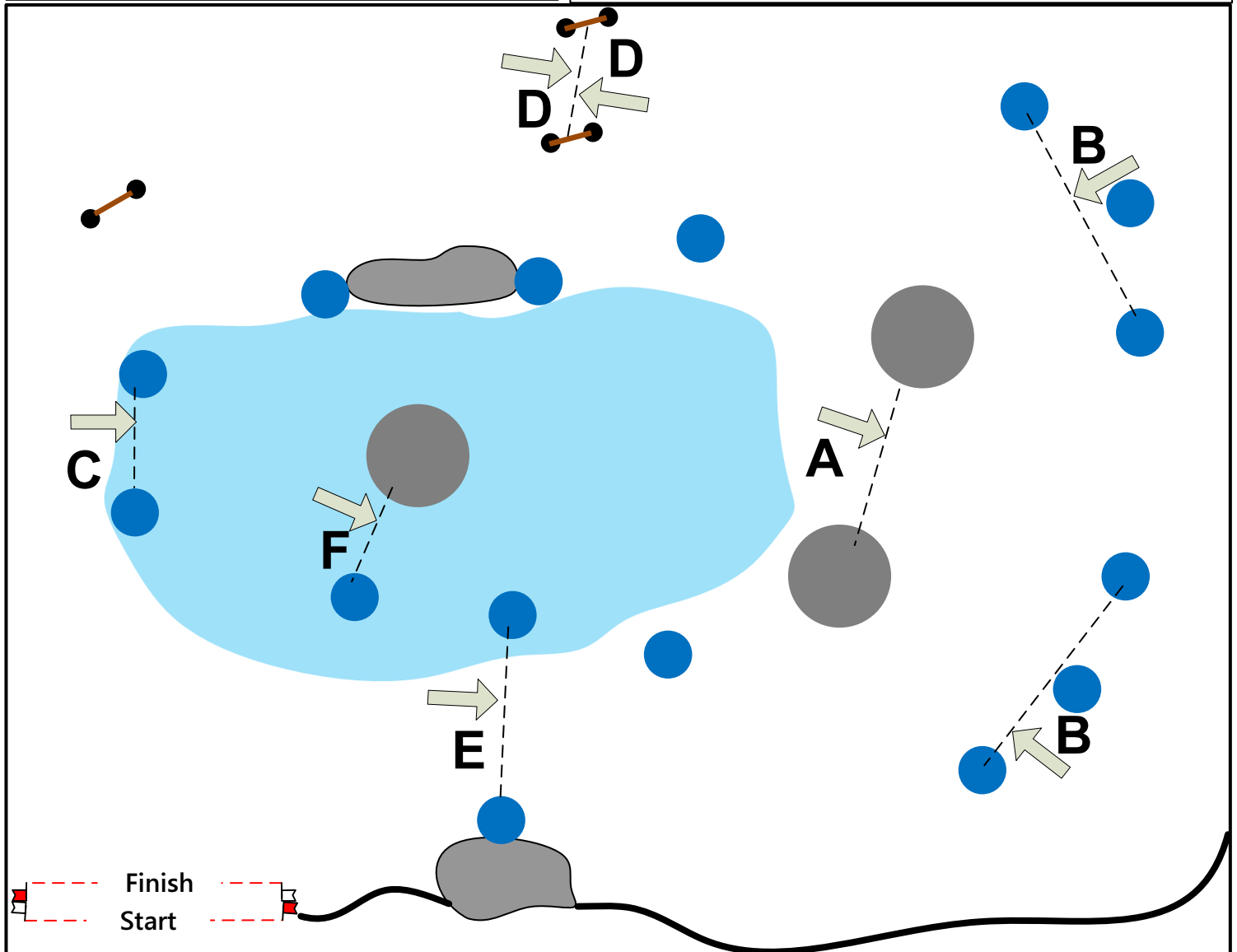



Internationales Fahrturnier
 International Driving Event
 CAI 3*/CAI 2*
 Nationales Fahrturnier
 CAN
 09.04.-12.04.2026

Hindernis
Obstacle **6**

Powered by:



Elektro Brinner
Brücke

CAI 3*

Not for CAI 2*

Geländefahren Kl. M Prfg.Nr: 40 nur

Tore A-E

Geländefahren Kl. A Prfg.Nr: 2; 6 und 10 nur

Tore A-D

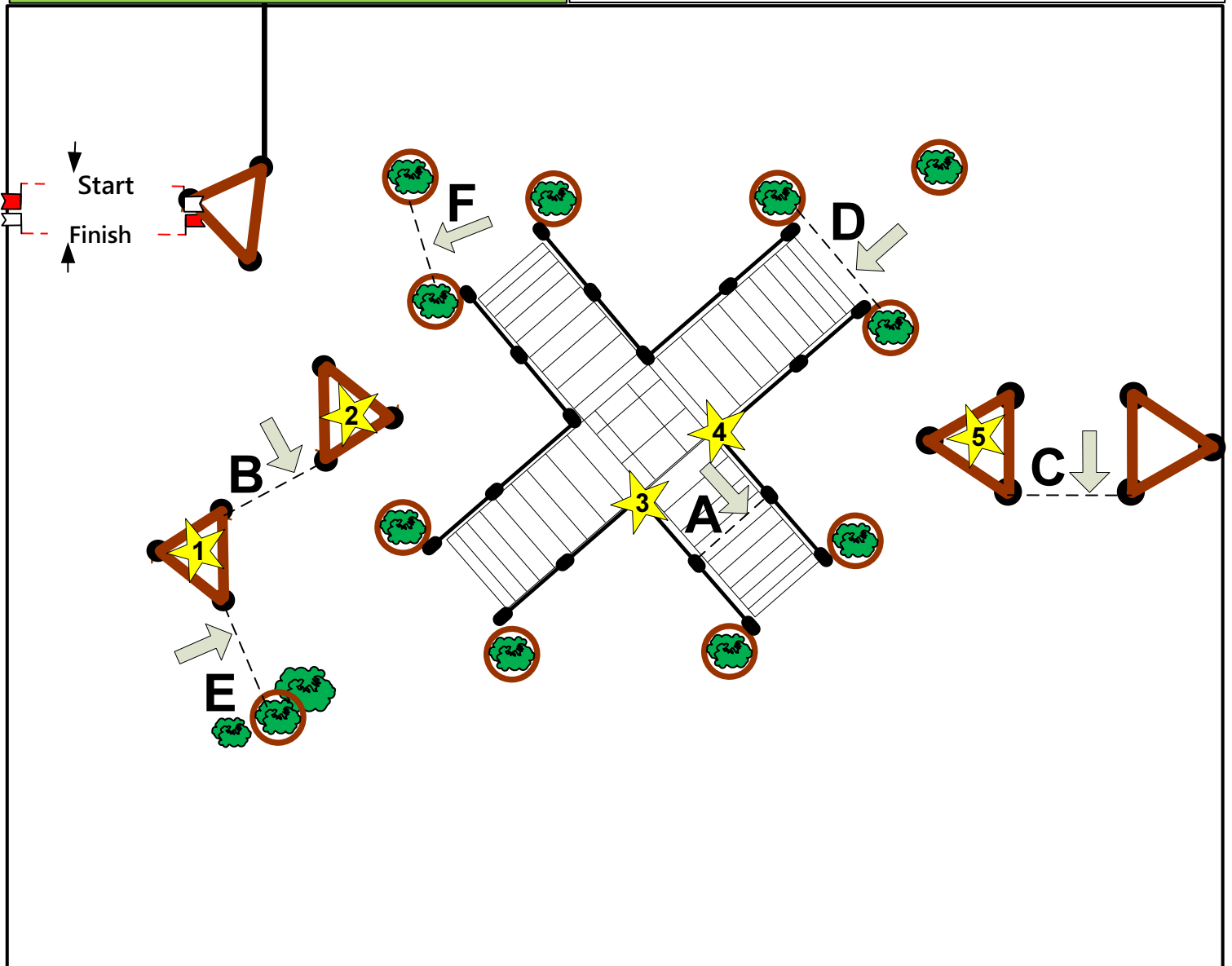

= 5 Knock Down

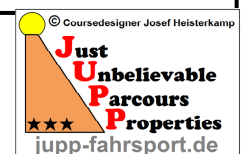



Fahr-und Reitverein Wettringen e.V.

Cones Competition

FEI Art. 970 - 981

Internationales Fahrturnier International Driving Event CAI 3*/CAI 2*

Nationales Fahrturnier CAN

09.04.-12.04.2026

Horse Single
Pony Single
Pony Pairs

2*

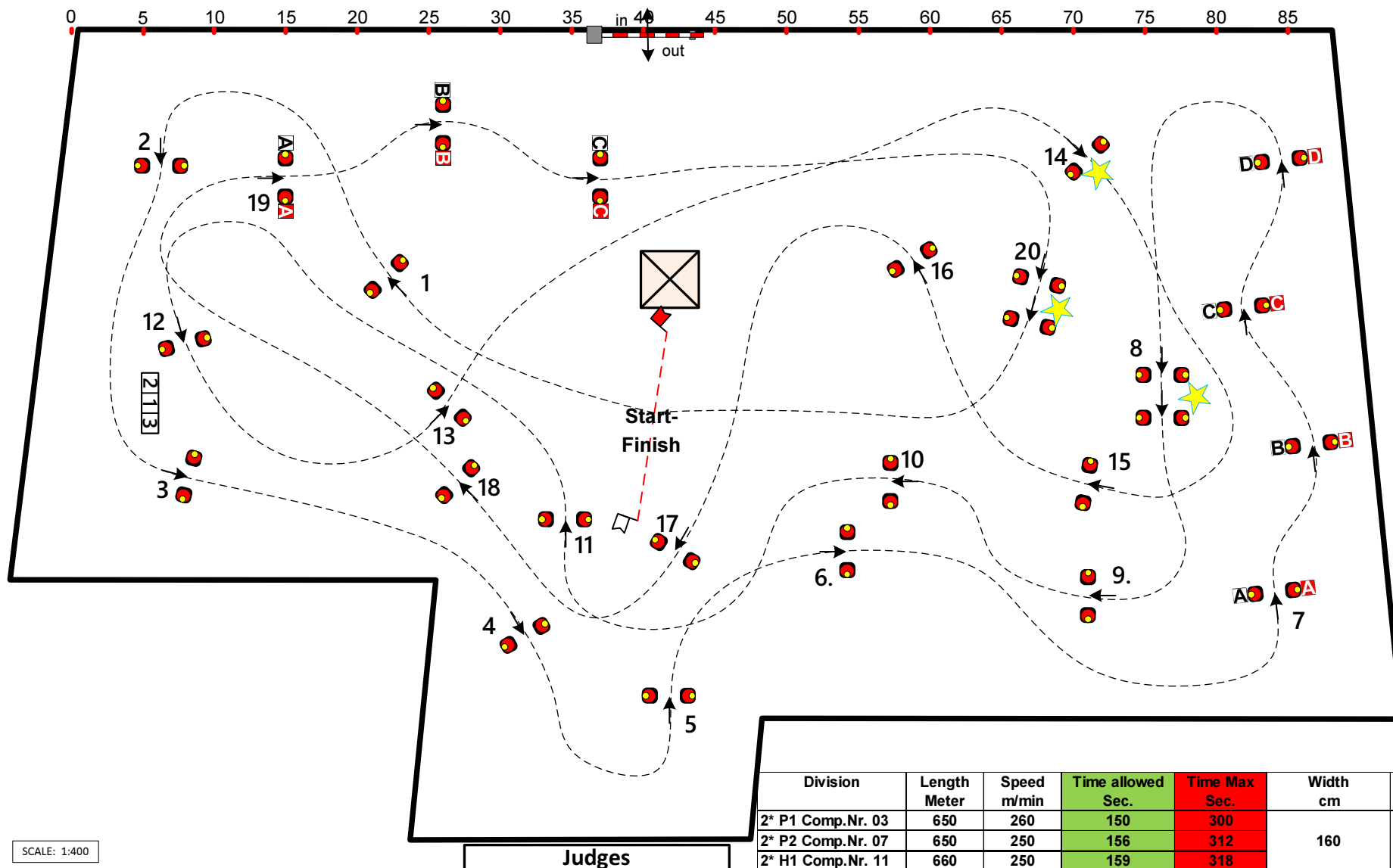

Division	Length Meter	Speed m/min	Time allowed Sec.	Time Max Sec.	Width cm	Width cm	Obstacles
2* P1 Comp.Nr. 03	650	260	150	300			
2* P2 Comp.Nr. 07	650	250	156	312	160	★-5	20
2* H1 Comp.Nr. 11	660	250	159	318			





Fahr-und Reitverein Wettringen e.V.

Cones Competition

FEI Art. 970 - 981

Internationales Fahrturnier International Driving Event CAI 3*/CAI 2*

Nationales Fahrturnier CAN

09.04.-12.04.2026

Horse Single

3*

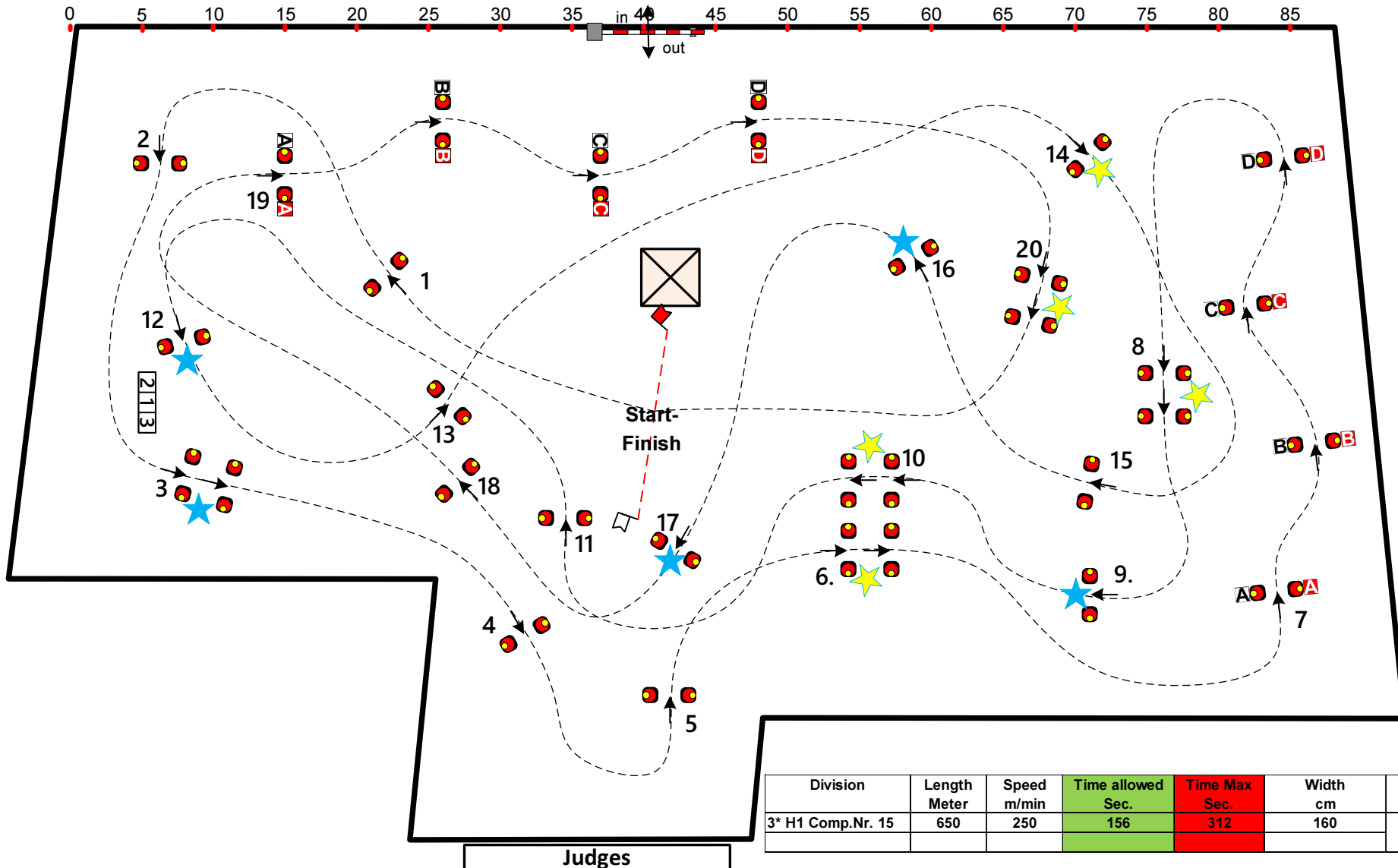

Division	Length Meter	Speed m/min	Time allowed Sec.	Time Max Sec.	Width cm	Width cm	Obstacles
3* H1 Comp.Nr. 15	650	250	156	312	160	★-5 ★	20



Internationales Fahrturnier
 International Driving Event
 CAI 3*/CAI 2*
 Nationales Fahrturnier
 CAN
 09.04.-12.04.2026

Dressur-/Kegel-Fahr-WB für Einspänner; Two in One (Stilwertung) mit Erlaubter Zeit Wertungs-WB zu Alberts Kids-Cup 2026

Richtv.: WB § 413

WB 21

K V E S H

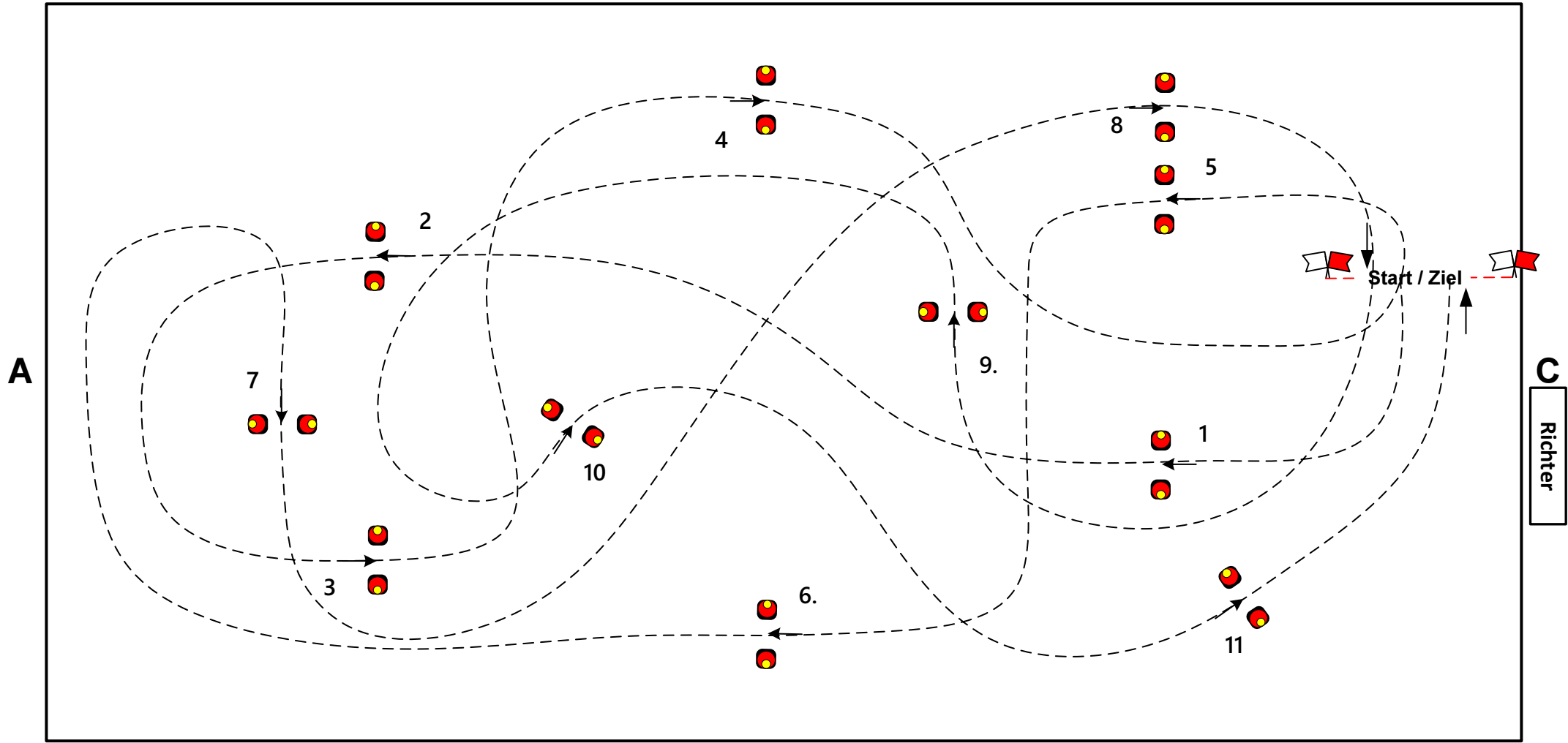

F P B R M

Richter	Richtverfahren WBO § 413			
	Hindernisse Anzahl	11	Tempo in m/min	180
	Hindernisbreite= Spur zuzüglich	40	Parcourslänge in m	560
			Erlaubte Zeit in sec	187
			Höchstzeit in sec	374

SCALE: 1:300

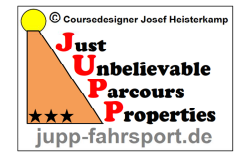



Fahr-und Reitverein Wettringen e.V.

Cones Competition

FEI Art. 970 - 981

Internationales Fahrturnier International Driving Event CAI 3*/CAI 2*

Nationales Fahrturnier CAN

09.04.-12.04.2026

Horse Pairs

3*

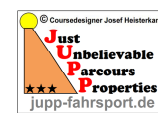
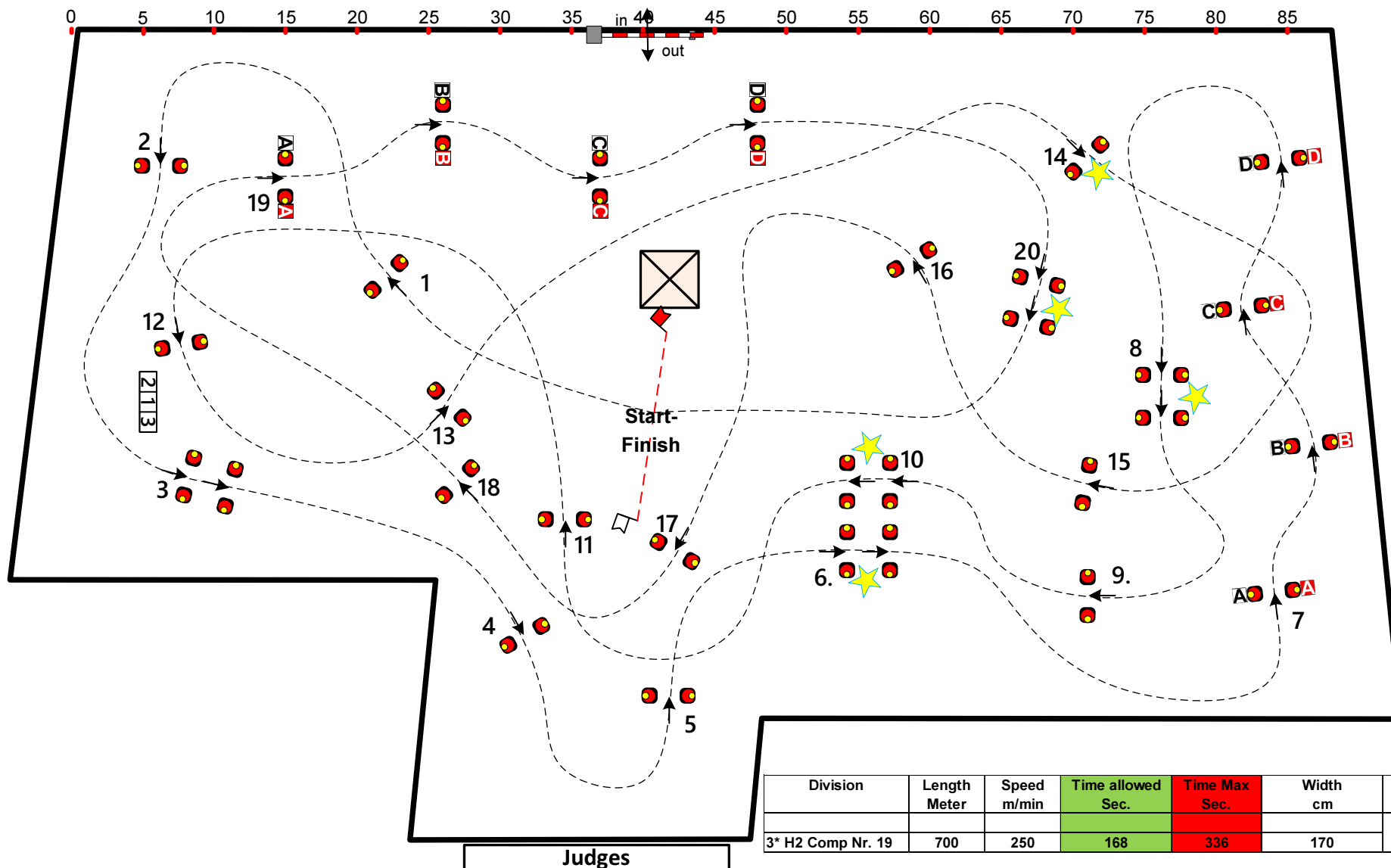

Division	Length Meter	Speed m/min	Time allowed Sec.	Time Max Sec.	Width cm	Width cm	Obstacles
3* H2 Comp Nr. 19	700	250	168	336	170	★ -5	20



Fahr-und Reitverein Wettringen e.V.

Kegel Fahrprüfung

LPO § 721.A

Internationales Fahrturnier International Driving Event CAI 3*/CAI 2*

Nationales Fahrturnier CAN

09.04.-12.04.2026

Pony Einspänner Pony Zweispanner Pferde Zweispanner

KI. A

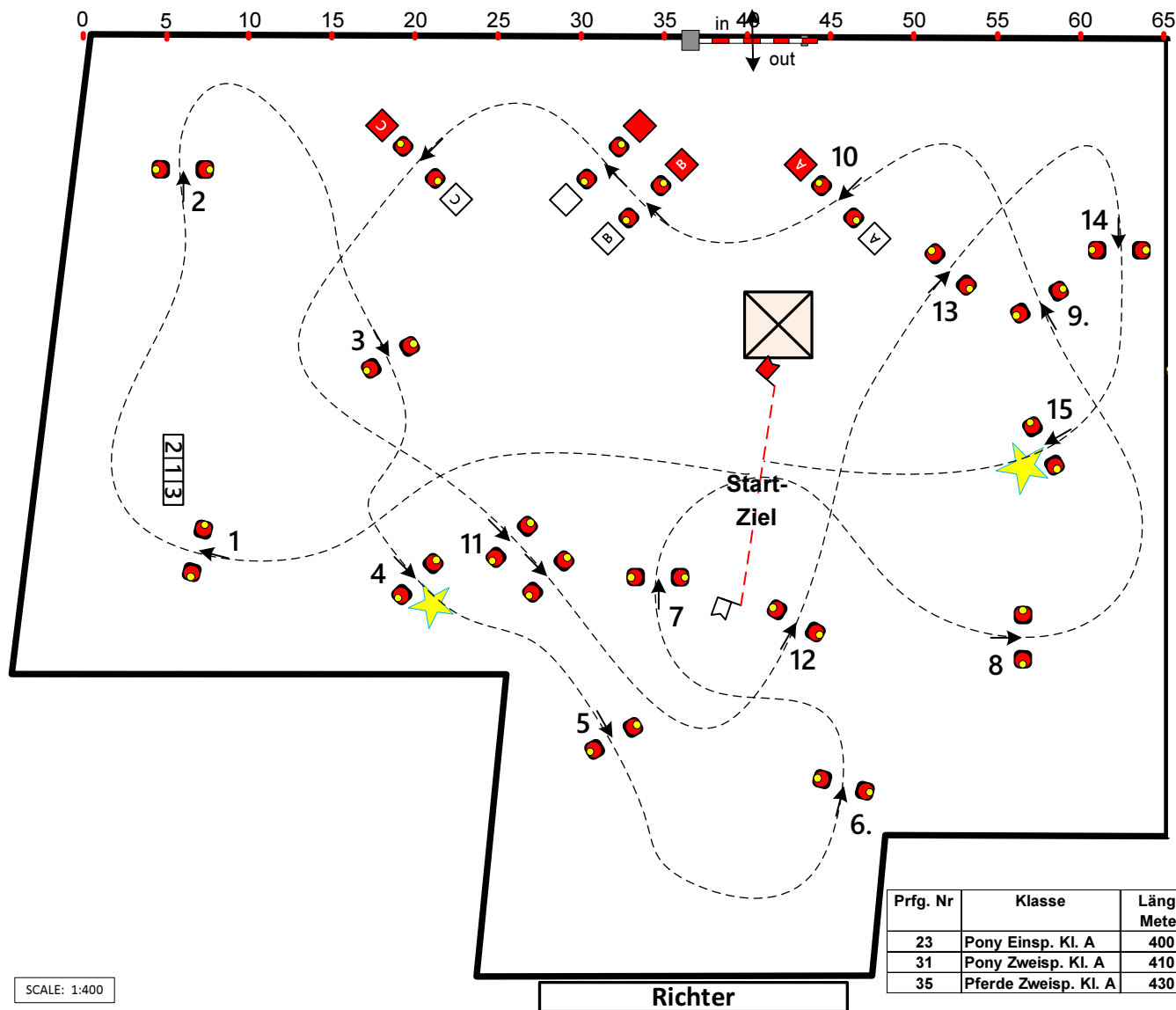

SCALE: 1:400

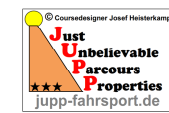

Prfg. Nr	Klasse	Länge Meter	Tempo m/min	Erlaubte Zeit Sec.	Höchstzeit Sec.	Hindernisbreite Spur + cm	Hindernisbreite Spur + cm	Hindernisse
23	Pony Einsp. Kl. A	400	230	105	210			
31	Pony Zweispann. Kl. A	410	230	107	214	25	★ 20	15
35	Pferde Zweispann. Kl. A	430	230	113	226			



Internationales Fahrturnier
 International Driving Event
 CAI 3*/CAI 2*
 Nationales Fahrturnier
 CAN
 09.04.-12.04.2026

Kegelfahren Klasse A
Prfg.:27
Pferde Einspanner
 Kegel Fahrprüfung
 LPO § 721.A

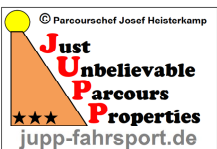
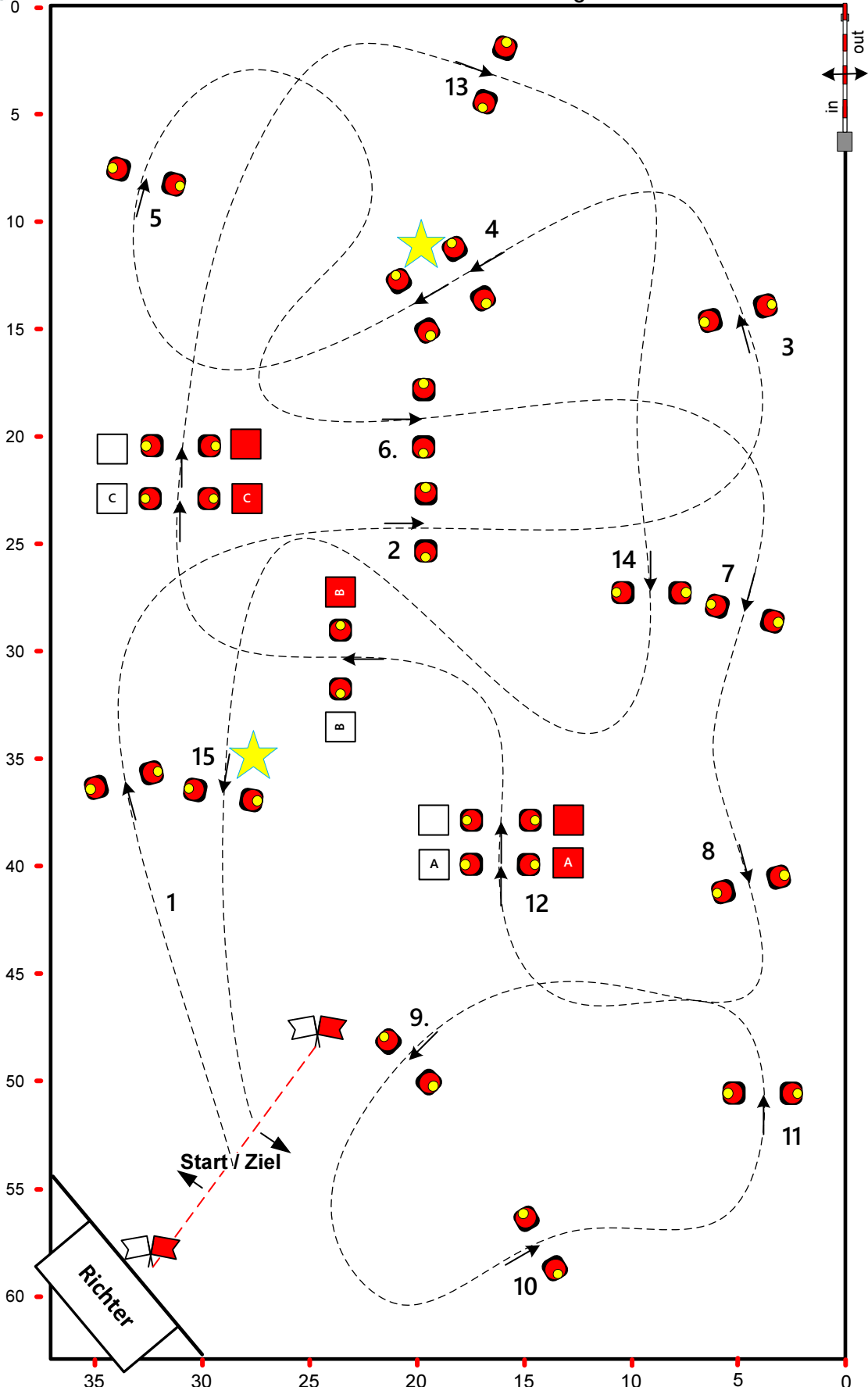

SCALE: 1:275

Prfg. Nr	Klasse	Länge Meter	Tempo m/min	Erlaubte Zeit Sec.	Höchstzeit Sec.	Hindernisbreite Spur + cm	Hindernisbreite ★ Spur + cm	Hindernisse
27	Pf 1Sp Kl. A	420	230	110	220	25	★ 20	15



Fahr-und Reitverein Wettringen e.V.

Kegel Fahrprüfung

LPO § 721.A

Internationales Fahrturnier International Driving Event

CAI 3*/CAI 2*

Nationales Fahrturnier CAN

09.04.-12.04.2026

Pony Vierspänner

KI. M

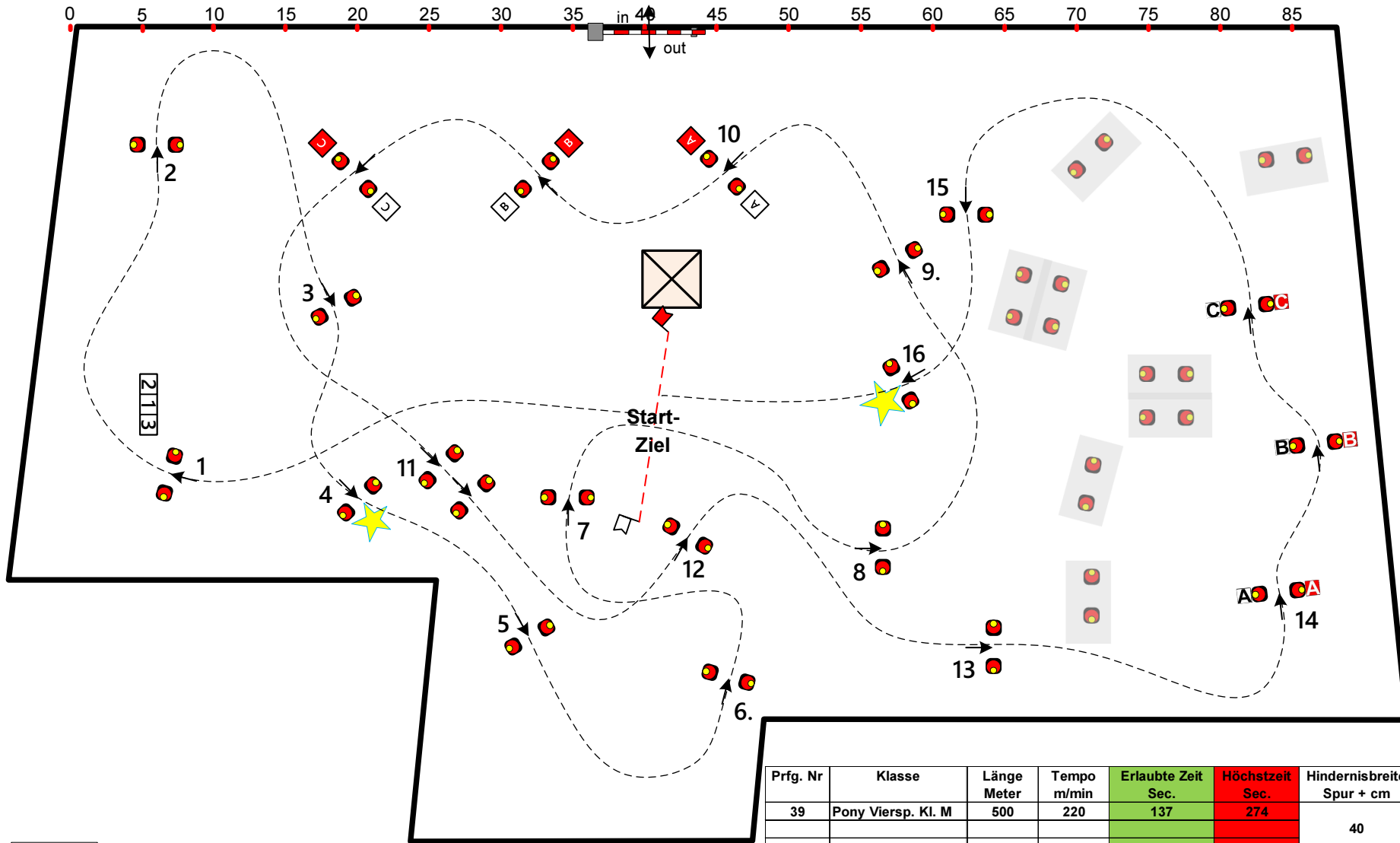

SCALE: 1:400

Richter

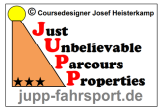

Prfg. Nr	Klasse	Länge Meter	Tempo m/min	Erlaubte Zeit Sec.	Höchstzeit Sec.	Hindernisbreite Spur + cm	Hindernisbreite Spur + cm	Hindernisse
39	Pony Viersp. KI. M	500	220	137	274	40	35	16